

Small filter box

Technical documentation



Legal notice



NOTICE

This documentation TD 004 032 only applies to the product described in chapter 1.

This documentation is subject to change or withdrawal without notice. The information specified in this documentation is applicable until they are changed by a newer version of the documentation (T number with new index). The user of the documentation is responsible for obtaining information on the latest version of the documentation from the publisher. Incorrect information provided in this documentation unknown to the publisher at the time of publishing shall not entitle to legal claims. Hand-written changes and supplements are invalid. The documentation is subject to copyright.

Foreign-language documentations according to the list in this documentation shall always be approved or changed simultaneously with the German version. In case of deviations in the foreign-language documentation, the German documentation shall apply.

In this documentation, some words are highlighted in **blue colour**. This indicates designations and identifications identical in all languages that are not translated.

Users of the documentation are asked to notify the publisher on incorrect or unclear information, errors, false statements etc.

© SECURITON GmbH, Von-Drais-Straße 33, 77885 Achern, Germany



NOTICE

Validity for manufacturing status

The following documentation shall only be valid for the filter box small with the following manufacturing status:

Manufacturing status

as of 010716

Safety instructions

Safety instructions

If the product is used by trained personnel in accordance with this documentation TD 004 032 and the risk, safety and general instructions in this technical documentation are observed, there is no risk to persons or property in case of normal and correct use.

National and country-specific laws, regulations and guidelines must be observed and complied with in any case.

Labelling, content and display of risk, safety and general instructions are listed below in this documentation:



DANGER

In case of non-compliance with danger warnings, the product or any other system parts may pose a hazard to persons and/or property or be damaged or malfunctioning in such a way that hazards to persons and property occur.

- Description of potential hazards;
- Measures and precautions;
- How the hazards can be averted;
- Any other safety-relevant information.



WARNING

The product may be damaged if the warning notice is not observed.

- Description of potential damage;
- Measures and precautions;
- How the hazards can be averted;
- Any other safety-relevant information.



NOTICE

The product may malfunction if the notice is not observed.

- Description of the notice and the malfunctions to be expected;
- Measures and precautions;
- Any other safety-relevant information.



RECYCLING / ENVIRONMENTAL PROTECTION

The product and its components do not cause any environmental damage if handled properly.

- Description of parts subject to requirements for environmental protection;
- Description of environmentally friendly disposal of devices or components;
- Description of recycling options.

Table of contents**Table of contents**

1	Field of application	7
2	Construction	7
3	Function	7
4	Mounting	7
4.1	Mounting filter mat	8
5	Maintenance and service	9
6	Article numbers	9
7	Technical data	10
8	Project planning notice	11
9	List of figures	13

1 Field of application

The filter box small is used as an accessory part for aspirating smoke detectors SecuriRAS® in areas with **low temperature conditions** (below 0°C) and high dust levels to prevent false alarms and to increase the lifespan of the smoke sensors substantially.

The filter insert is designed for the separation of particles and impurities. Due their particle size, smoke particles can pass through this filter unhindered. Reliable and fast fire detection is thus ensured.

2 Construction

The filter box small is part of the suction pipe. The housing is made of polycarbonate, light grey paint (RAL 7035). The filter box can be opened using the 4 cover screws in order to clean the filter mat small for servicing work and to change it.

3 Function

The air polluted with dust particles is also aspirated by the aspirating smoke detector. To prevent false alarms, the aspirated air must be purified of these particles. The filter box small can be used for this purpose as an additional accessory component.

This is to be arranged directly in front of the evaluation unit in the suction pipe (see project planning notice). The aspirated air is conducted across the filter mat to filter the dust particles. If the filter mat is contaminated, it should be replaced during maintenance.

Advantages of the filter box small

- Prevention or substantial reduction of false alarms
- Lengthening of lifespan of smoke sensors
- Very low installation costs
- Subsequent installation possible at any time
- Low operating costs
- Applicable for all aspirating smoke detectors
- Quick, clean and inexpensive solution
- **Field of application deep freeze area**

4 Mounting

The filter box small must always be installed below the aspirating smoke detector to prevent false alarms due falling dust particles. If the formation of ice (at temperatures up to -30°C) can be expected at the suction openings, a wire connection unit WCU 535 should be installed in front of the filter box in accordance with the application guidelines for deep freeze stores (T 131 390D). Assembly and arrangement should be carried out in accordance with the project planning notice.

Mounting

4.1 Mounting filter mat

to the aspirating smoke detector
SecuriRAS® ASD 53-x

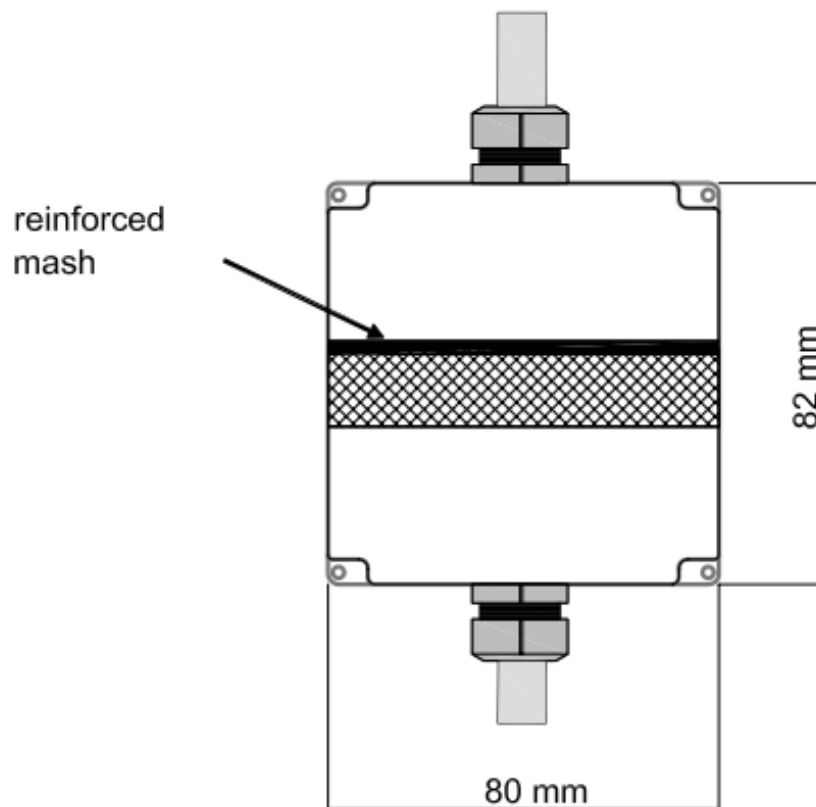

to the sampling pipe

Abb. 1 Mounting orientation filter box small

5 Maintenance and service

When carrying out maintenance work on the aspirating smoke detector, the filter mat should be replaced for the filter box "small", if necessary, and contamination within the filter box should be removed.

The Filter mat has to be placed with the mesh side to the ASD and the fleece side in direction of the Suction line.

Furthermore, the technical documentation of the respective aspirating smoke detector must be considered.



WARNING

Maintenance and service work on fire alarm systems are subject in part to country-specific laws and directives.

Maintenance and service work may be performed only by persons trained and authorised by the manufacturer of the aspirating smoke detector.

6 Article numbers

Abbreviated designation		Art. No. SECURITON
Aspirating smoke detector SecuriRAS® ASD 535-1		5000623-0101
Aspirating smoke detector SecuriRAS® ASD 535-2		5000623-0102
Aspirating smoke detector SecuriRAS® ASD 535-3		5000623-0103
Aspirating smoke detector SecuriRAS® ASD 535-4		5000623-0104
Smoke sensor SSD 535-1		5000613-0101
Smoke sensor SSD 535-1 CP		5000613-2201
Smoke sensor SSD 535-2		5000613-0102
Smoke sensor SSD 535-2 CP		5000613-2202
Smoke sensor SSD 535-3		5000613-0103
Smoke sensor SSD 535-3		5000613-2203
Filter box small d=25	FBS 25 PC	50-0500143-01-01
Filter mat, small (white)		0.100229
Wire connection unit WCU 535 PC	WCU 535 PC	500635-0101
Manual ball cock PVC	MV 25 PVC	50-0500175-01-xx
Manual ball cock PVC with safety lock		50-0500175-02-xx
Manual ball cock ABS	MV 25 ABS	50-0500174-01-xx
Manual ball cock ABS with safety lock		50-0500174-02-xx
Wire connection unit WCU 535 PC	WCU 535 PC	500635-0101

Technical data

7 Technical data

Features	
Environmental conditions	
Expanded environmental conditions:	
• Temperature range	-30 to +60 °C
Introduction	2x screw connections M32 incl. sealing mm
Housing material	Polycarbonate (PC)
Housing colour	Light grey 7035 RAL
Approval	
VdS	G 208154
Building product approval	0768-CPD-20600
Dimensions (H x W x D)	80 x 82 x 85 mm
Weight	max. 300 g

Subject to technical modification!

8 Project planning notice



Abb. 2 Standard installation

Project planning notice

Optional:

**With wire connection unit WCU 535
(for use in deep freeze area)**

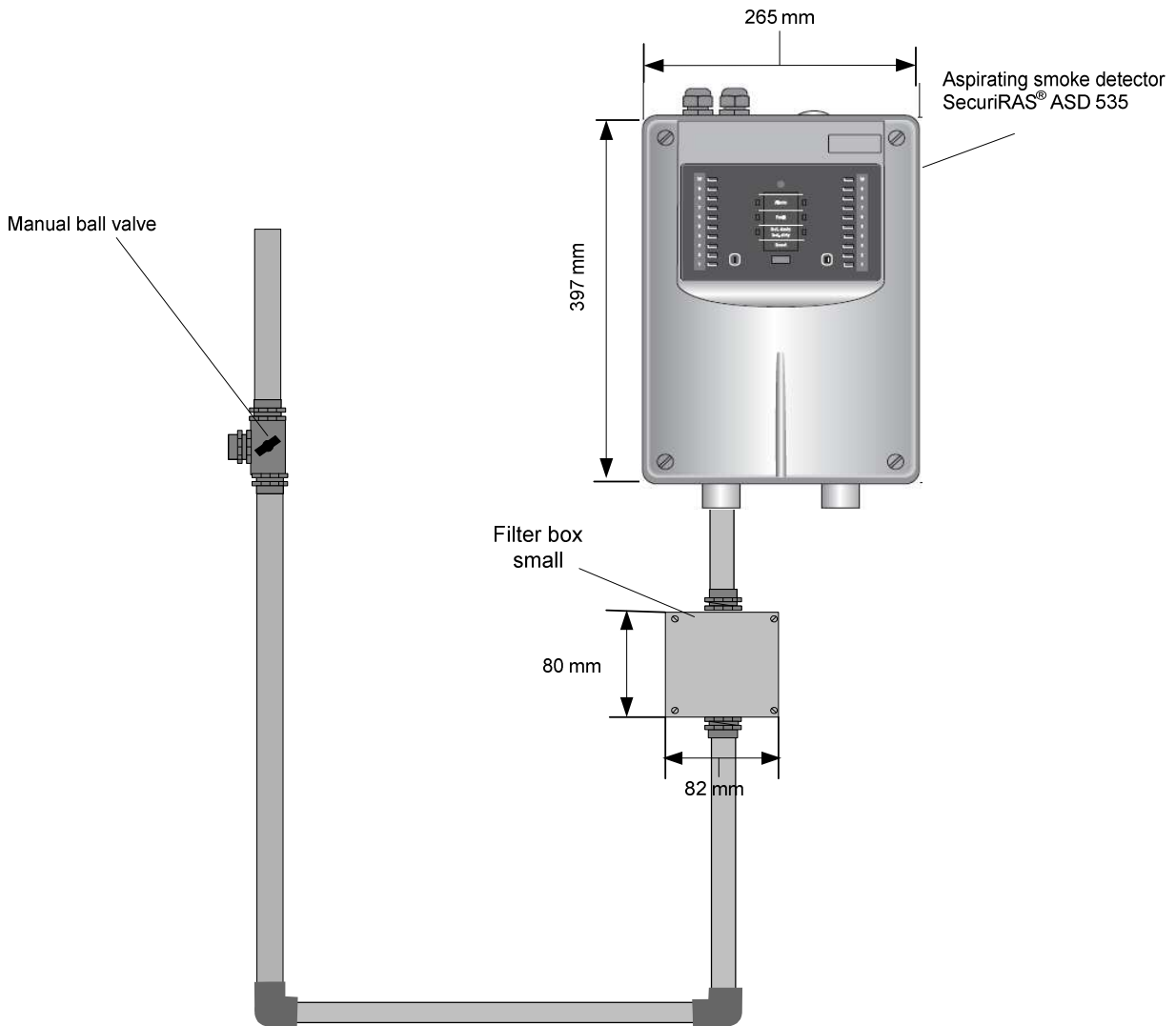
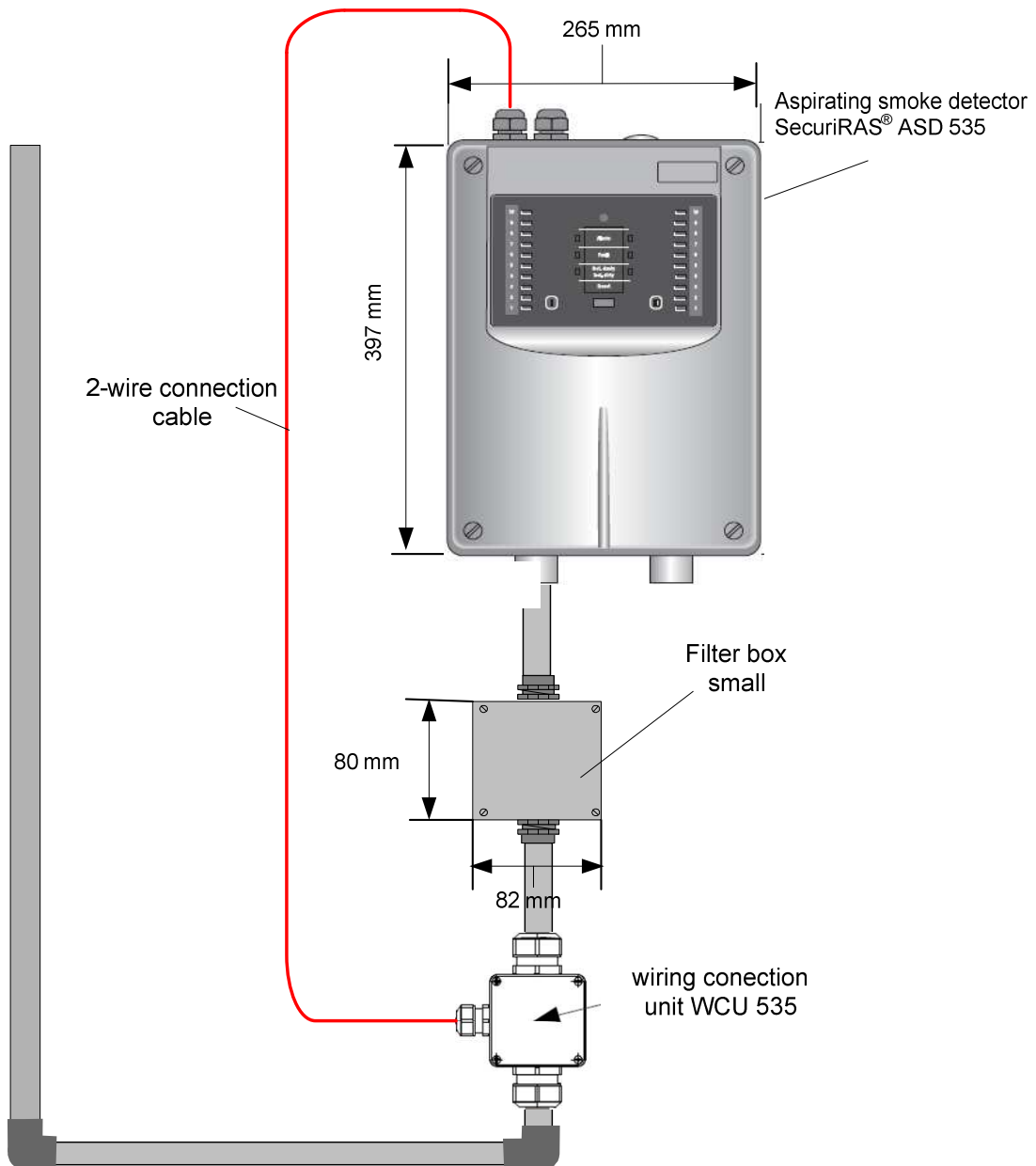

Abb. 3 Standard installation with wire connection unit WCU 535

9 List of figures

Abb. 1 Mounting orientation filter box small.....	8
Abb. 2 Standard installation	11
Abb. 3 Standard installation with wire connection unit WCU 535	12